

**EE168S**



- **Built for Security Professionals by Security Professionals**

The **PanGuard / EE168S** fully supervised security back-up unit dramatically enhances security for standalone wireless and partial protection systems. Will also provide additional features for full protection security systems.

This standard single-gang, flush mount unit was designed to prevent tampering of control panels, telephone lines, other alert devices (sirens, bells, strobes, horns, etc.) or CCTV (camera) and electronic equipment systems. Battery operated (9VDC) with built-in 110db siren. Unit is operational in both the armed or disarmed status. Utilizing EESGI patented Technology, the microprocessor of PanGuard / EE168S controls and supervises multiple functions. Unique built-in status monitor provides identifiable audible system trouble indicator. These distinct beeps alert the end-user for low battery condition, open siren loop, telephone line disable, and aux power status. Built-in external siren output short protection device. Selectable siren output for auto cut-off for either 3 minutes (recommended for residential ) or 8 minutes (recommended for commercial).

PanGuard / EE168S provides the end user with additional protection and alarm dealers additional benefits and cost savings. Fit into the decor of an existing residential or commercial environment.

Control Module

2-1

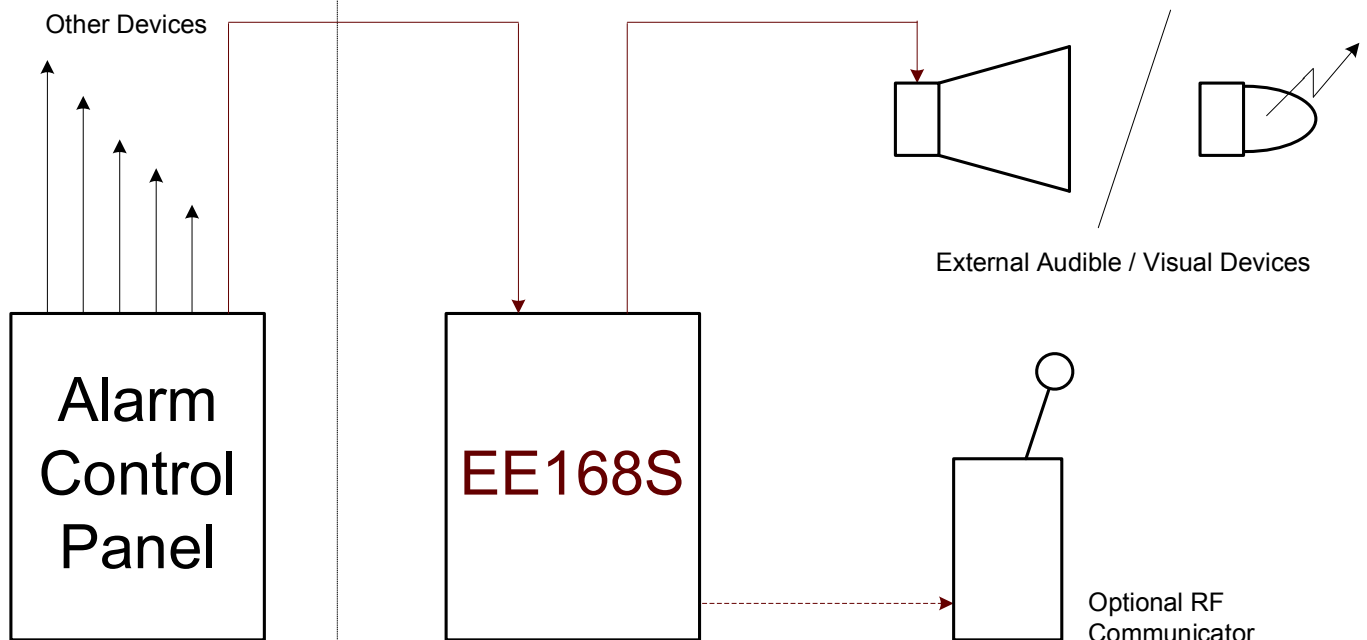

**EE168S**



**Application for CCTV / Other Electronic Equipment**

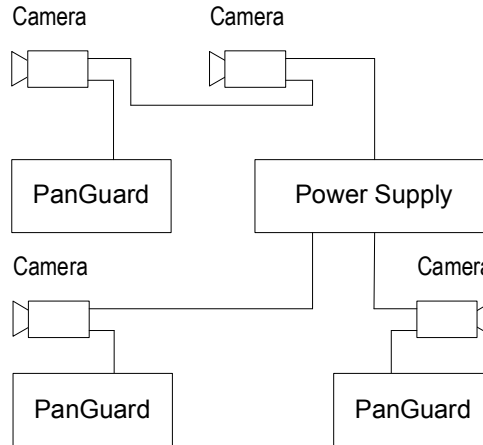

**Application for Fire Alarm (Phone Line Supervised)**

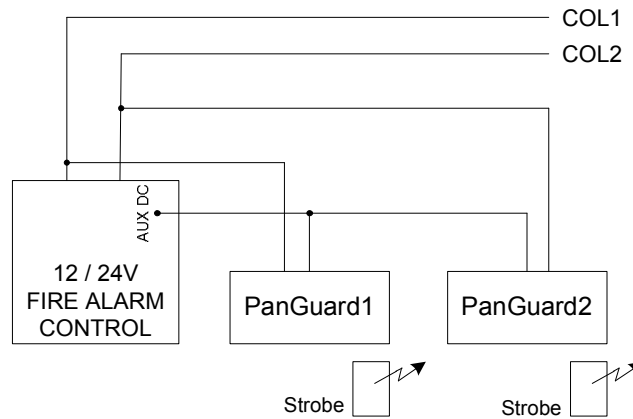

Control Module

22

**SPECIFICATIONS:**

Sensing Voltage:	4 - 120V AC/DC
Current Consumption:	0.004MA Standby, 700MA Max in Alarm
Siren Output:	700MA Max
Standby Battery:	9VDC / Alkaline
Dimension:	4.5" x 2.75" x 1.25" w/o battery

**FEATURES & BENEFITS:**

- Universal Usage, Compatible with all security control panels and CCTV camera system
- Automatic Status Indicator, Distinct beeps alerts user for low battery condition, open siren loop, telephone line disable and auxiliary power status
- Functions as a Siren, Compatible with all security control panels and most CCTV camera systems
- Siren Output Protection, Automatically cut off output when shorted to prevent and damage during installation and service
- Constant Operation, Unit is operational in the armed or disarmed status
- Programming Free, No programming or DIP switches to set
- Easy Installation, Standard single-gang, flush mount unit that can be installed anywhere on the premises. Paintable surface for décor matching.
- Selectable Siren Auto Cut-off, Siren output is selectable for auto cut-off for either residential or commercial uses.
- Output Drives Long Range Radio, Can be used to trigger long range radio. Signal will be sent even when the alarm panel has been disabled.
- Outputs for external Sirens / Speakers, Outputs can drive up to 30 watt sirens or 15 watt speakers